

## ROHR2 Interfaces

Program System ROHR2  
Interfaces - Overview and Details

SIGMA Ingenieurgesellschaft mbH



<b>Contents</b>	1	Integration of ROHR2.....	1
	2	Interfaces to CAD-Systems.....	2
	2.1	2D CAD-Systems - Overview.....	2
	2.2	Neutral Interface .....	3
	2.3	Interface PDMS - ROHR2.....	5
	2.4	Interface INTERGRAPH-PDS - ROHR2 .....	6
	2.5	Interface INTERGRAPH-SMARTPLANT - ROHR2 .....	6
	2.6	Interface Alias PCF .....	7
	2.7	Interface AUTOPLANT PXF- ROHR2.....	7
	2.8	Interface PASCE - ROHR2.....	8
	2.9	Export of graphics.....	8
	3	Interfaces to Steel construction programs.....	8
	3.1	Interface SDNF - ROHR2 .....	8
	4	Interfaces to CAE-Systems .....	9
	4.1	ROHR2 - SINETZ Export Interface .....	9
	4.2	Interface ROHR2 - CAESAR II .....	9
	4.3	KWUROHR -ROHR2 Import Interface .....	10
	4.4	Fluid dynamic programs .....	10
	4.5	Interface ROHR2 - LICAD .....	10
	4.6	Interface ROHR2 - CASCADE.....	10
	5	Third Party Interfaces.....	11

**Software  
Development,  
Sales and  
Support**

**SIGMA** Ingenieurgesellschaft mbH  
Bertha-von-Suttner-Allee 19  
D-59423 Unna

Germany

Telephone      +49 (0)2303 332 33-0  
Fax                +49 (0)2303 332 33-50  
Email:            info@rohr2.de  
Internet:        www.rohr2.de  
                      www.rohr2.com

All of the mentioned products and brand names are trademarks or indexed trademarks of the respective manufacturers.

*Release 10.2009*

# 1 Integration of ROHR2

The program system ROHR2 is the CAE System for Component analysis, Engineering and Structure Analysis of Piping Systems.

Several interfaces are part of the "standard" ROHR2 program: besides several document and graphic file types the ROHR2 standard program delivery includes:

- Neutral CAD Interface, enables import from CAD/CAE systems like PDMS, CADISON, RC-Planet, HICADnext, and others
- Interface Export PDMS - ROHR2
- Caesar II Interface
- Export interface to SINETZ
- Export Interface into the Support Design Program LICAD and CASCADE  
(For further details please refer to the ROHR2 program description)

Additionally a variety of interfaces to CAD/CAE-systems are available to integrate ROHR2 into your workflow. The integration of ROHR2 is completed by third-party interface products.

Concerning the optimization of your workflow our staff of specialists will advise you individually upon request, especially regarding the data import and export to ROHR2.

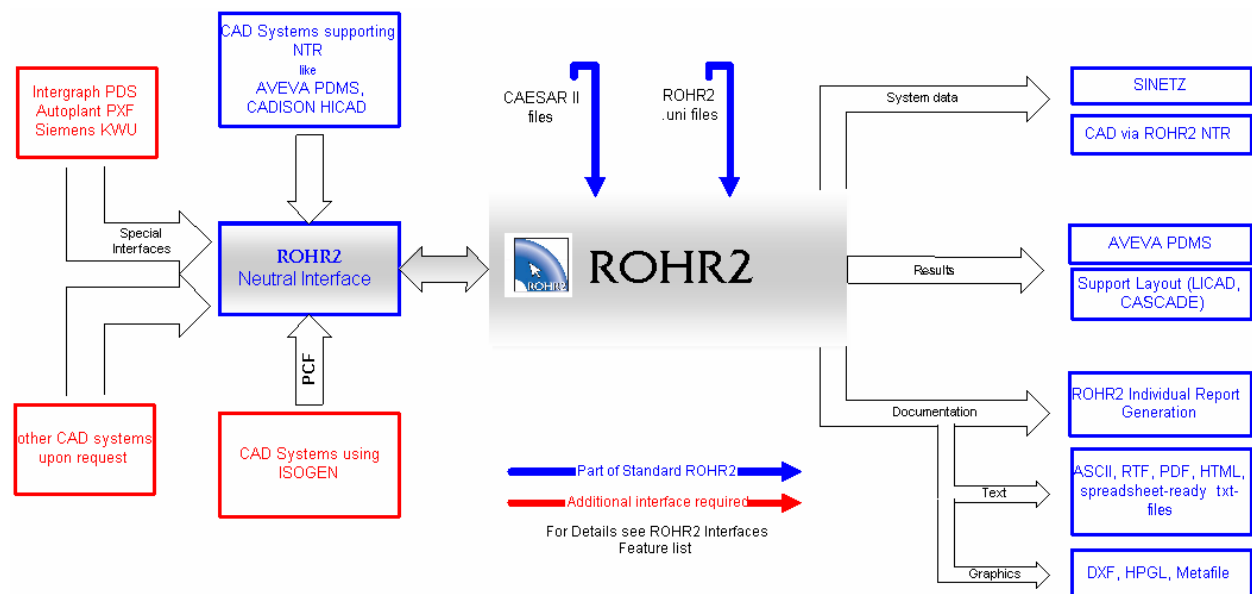



## 2 Interfaces to CAD-Systems

The data for generating a pipe model in ROHR2 is done by importing files from 3D Plant engineering systems by integrated interfaces (some of them optionally available).

This way to import data is basing on integrated component databases or database reports instead of simple graphic data. This enables to get more information than a simple piping structure, like assignment of materials, dimensions or support positions, required for the modeling in the ROHR2 pipe s stress calculation ROHR2

The creation of a piping model by means of graphics data information (e. g. AUTOCAD \*.dwg) allows to generate a geometry model in best case. ROHR2 does not support this working method, because modeling in ROHR2win is the more efficient way to get a piping model.

### 2.1 2D CAD-Systems - Overview

These CAD-systems are currently supported by ROHR2.

AVEVA PDMS	see 2.3	included in ROHR2, additional module on CAD side may be required
CADISON		
HiCADnext		
ROHR2CAD / RC-PLANET		
INTERGRAPH - PDS Stress interface	see 2.4	optional available
INTERGRAPH - SMARTPLANT	see 2.5	optional ROHR2 Interface in preparation or via PCF interface
Alias PCF Format, ISOGEN	see 2.6	optional available
AUTOPLANT PXF	see 2.7	optional available
PASCE AEA Technology Engineering Software	see 2.8	optional available
SDNF Format (Steel Detailing Neutral File)	see 3	optional available

Please ask for detailed information and sample files.

The ROHR2 Neutral Interface is the main program module for the integration of CAD-programs (for details please refer to 2.2).

The neutral interface and specific interface programs are additional programs included in ROHR2. They may be acquired as an upgrade to existing ROHR2 program installations.

Automatic generation of the ROHR2 input data from CAD-systems, in detail (if available):

- Geometry data
- Diameter
- Wall thickness`
- Materials
- Support points and support conditions
- Tees
- Instruments
- Flanges
- Expansion joints
- Reducers
- Design data
- Operation data

Enables automatic generation of the load cases dead weight, medium weight and operation.

Structure plot, deformed structures and the calculation model can be exported for further treatment.

Other available CAD-interfaces upon request.

## 2.2 Neutral Interface

Interface for data exchange between ROHR2 and optional available ROHR2 Interfaces as well as various CAD-systems like

- AVEVA PDMS
- CADISON
- HiCADnext
- ROHR2CAD / RC-PLANET

To simplify the data interchange with CAD systems, the format of the neutral interface was defined. Being based on the listing of all elements in the system (pipe, bend, instruments, supports, ...) it can be created e.g. by a report from a database.

For each element parameters required by ROHR2 have to be indicated.

But only a part of the parameters must be entered by the user, not indicated parameters are filled with standard values or calculated from other parameters. The elements are written into an ASCII file as data sets with defined record label and corresponding parameters.

### General description

- For each element a reference string may be entered to identify the element after the conversion from ROHR2 to the CAD-System.
- Input records can be in arbitrary order.
- Parameters within an input record can be in arbitrary order.
- Only a part of the parameters must be entered by the user, not indicated parameters are filled with standard values or calculated from other parameters.
- Insert coordinates by node name or directly. If the coordinates are put in directly, node names are created automatically
- All existing names in the MATDAT file may be used as material name. A translation table for the names, not included in MATDAT, may be created.
- All data from the ROHR2 databases can be used
- The expected file extension is \*.ntr.

### Defined pipe elements

The following pipe components are defined:

- Straight pipe
- Structural sections (profiles)
- Bend
- Reinforced tee
- Weldolet
- Tee (fitting)
- Reducer
- Flange
- Instrument
- Angle valve
- 3-, 4-way valve
- Axial expansion joint
- Angular expansion joint
- Lateral expansion joint
- Any rigid element with 2 connections

The coordinates of the start and end points must be indicated for each pipe element.

Not defined parameters like material or loads are replaced by default values.  
Line masses are given or calculated according to the dimensions.

## Defined support types

Any type of support may be converted. Support types are pre-defined for frequently used supports, e.g.:

Support type	Support direction
Spring hanger	Vertical translations
Rigid hanger	Vertical translations
Constant hanger	Vertical translations
Fixed point	All translations and rotations
Guide bearing	Translations cross to pipe axis (horizontal and vertical)
Slide bearing	Vertical translations
Axial stop	Translations in pipe axis
Transverse stop	All horizontal translations cross to pipe axis
Guide bearing with axial stop	All translations
Slide bearing with axial stop	Vertical translations and the translations in pipe axis are fixed
Transverse- and Axial stop	Horizontal transverse motions and the translations in pipe axis are fixed
Spring support	Vertical translations. The spring rate works in vertical direction
Spring support with bearing	All translations cross to pipe axis (horizontal and vertical). The spring rate works in vertical direction
Angulating support	Given support direction

At supports the friction coefficient and support gap may be put in for each direction.

## Programming interface

The programming interface integrates user defined interfaces for CAD-Systems into ROHR2WIN. By using *File open* data can be put in by other CAD systems directly on this way. This user specified interfaces must have 32-Bit Windows DLL format and have to convert the format of the CAD system into the format of the neutral interface (see description neutral interface). The ROHR2WIN-output window can be used for representation of the screen output during the conversion.

The programming interface is part of the Neutral interface (included).

## 2.3 Interface PDMS - ROHR2

Interface between the CAD-System PDMS and ROHR2.

The data transfer from PDMS to ROHR2 is carried out by the ROHR2 Neutral interface. Additionally the export of calculation results to PDMS is done by the ROHR2 integrated PDMS export function.

Requirements of the data transfer:

- the CAD-System PDMS
  - The PDMS System must be equipped with a **PDMS ROHR2 Interface**.
  - This Interface to generate data from the CAD system PDMS in a format, readable by the ROHR2 Neutral Interface is a separate available product of AVEVA GmbH, D-65843 Sulzbach.
- a current program license of ROHR2 incl. ROHR2WIN and
  - for the **import of data**: a ROHR2 neutral interface
  - for the **import and export of data**: a ROHR2 neutral interface with the additional ROHR2-PDMS export function.

Die neutral interface and the ROHR2-PDMS interface are part of the program system ROHR2.

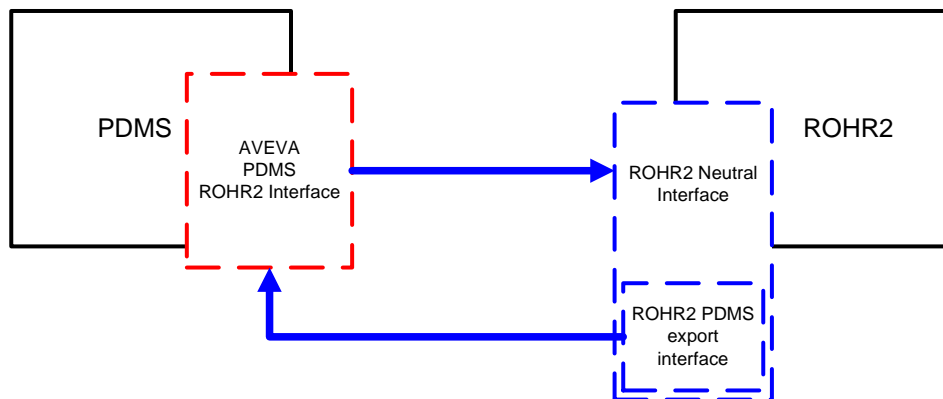

The data exchange process:

### 1. Transfer from PDMS to ROHR2 (import of data into ROHR2)

The conversion from PDMS to ROHR2 is carried out in two steps:

- The PDMS Interface creates data in the format of the ROHR2 neutral interface.
  - The scope of conversion depends on the parameters defined by PDMS.
- The created .NTR-file is read by the neutral interface (integrated in ROHR2WIN).

The complete pipe geometry incl. materials, insulation and design data details as well as support types are taken over in details, if they are defined in PDMS (corresp. attribute must be set in PDMS)

### 2. Transfer ROHR2 to PDMS (ROHR2 data export)

The data export from ROHR2 to PDMS includes load case dependent support results and deformations.

It is carried out in two steps, too:

- data is written into PDMS adapted export files.
- The files are taken over by the PDMS Interface into the PDMS model and shown.

Deformed structures may be represented in PDMS by this way. Beyond that, in PDMS calculation results are stored for further treatment, e.g. in hanger design software.

Please ask for detailed information and sample files.

## 2.4 Interface INTERGRAPH-PDS - ROHR2

Interface to convert the output data from the PDS Stress Interface, Intergraph Corporation into the ROHR2 neutral file format.

The import of Intergraph-PDS data into ROHR2 is carried out by the PDS Stress Interface.

Requirements of the data transfer:

- the current program license ROHR2 incl. ROHR2WIN
- the Interface Intergraph PDS - ROHR2
- the ROHR2 Neutral Interface

The conversion is carried out by two steps:

- The PDS Interface creates data in the format of the ROHR2 neutral interface.  
The scope of conversion depends on the parameters defined by Intergraph PDS.
- The created .NTR-file is read by the neutral interface (integrated in ROHR2WIN).

The neutral interface requires a file format to be created by the Intergraph PDS Stress Interface, which can be adjusted by means of the configuration file DEFAULTS.DAT.

A template file DEFAULTS.DAT is available.

The data conversion into the neutral interface format is controlled by the parameter file ign.env. Materials, support conditions as well as expansion joint parameters are determined by tables from the PDS data.

### Components to be transformed

Components of the Intergraph PDS Stress Interface to be converted are:

Generic name (PDS)	Meaning
3W	3-way valve
4W	4-way valve
AV	Angle valve
CR	Crossing
EL	Bend
ER	Eccentric reducer
FL	Flange
HA	Support
MT	Miter (Segment)
PI	Pipe
RB	Rigid Body
RD	Concentric reducer
RI	Bending
TE	Tee
TF	Welded nozzle
VA	Instrument
FX	Expansion joint

## 2.5 Interface INTERGRAPH-SMARTPLANT - ROHR2

The direct interface ROHR2 to Intergraph SMARTPLANT is in test phase now. There will be no need for an additional interface at ROHR2 side.

At this moment the import of SMARTPLANT CAD-Data into ROHR2 may be carried out by means of the PCF-interface.

If details about the SMARTPLANT export format are available, an interface SMARTPLANT - ROHR2 will be realized.

## 2.6 Interface Alias PCF

The interface Alias PCF - ROHR2 enables to convert data in PCF format into ROHR2. The PCF format is used by several CAD-systems creating isometrics by the program ISOGEN, by Alias Ltd.UK, [www.alias.ltd.uk](http://www.alias.ltd.uk).

Applications, supporting ISOGEN format are, e.g.:

- Pro/ENGINEER
- TRICAD MS,
- AUTOCAD Inventor Professional

By means of this interfaces, data of several CAD systems may be imported into ROHR2. A configuration file is used to adapt the interface to the data, produced by the CAD-system

The interface ALIAS PCF- ROHR2 is an optional available program module to be integrated into ROHR2.

Requirements of the data transfer:

- - a current program license of ROHR2 incl. ROHR2WIN
- - the Interface Alias PCF- ROHR2
- - the ROHR2 Neutral interface

The conversion is carried out in two steps:

- The PCF Interface creates data in the format of the ROHR2 neutral interface.
- The created .NTR-file is read by the neutral interface (integrated in ROHR2WIN).

Please ask for detailed information and sample files.

## 2.7 Interface AUTOPLANT PXF- ROHR2

Interface to convert data from PXF format (Bentley AUTOPLANT) into the ROHR2 neutral interface format.

The interface AUTOPLANT PXF - ROHR2 is an optional available program module to be integrated into ROHR2.

Requirements of the data transfer:

- a current program license of ROHR2 incl. ROHR2WIN
- the Interface AUTOPLANT ROHR2
- the ROHR2 Neutral interface

The conversion is carried out in two steps:

- The PXF Interface creates data in the format of the ROHR2 neutral interface.  
The scope of conversion depends on the parameters defined by AUTOPLANT.
- The created .NTR-file is read by the neutral interface (integrated in ROHR2WIN).

## 2.8 Interface PASCE - ROHR2

Interface to transmit the output data of the PASCE Stress Interface, AEA Technology Engineering Software, into the ROHR2 neutral interface format.

The interface PASCE - ROHR2 is an optional available program module to be integrated into ROHR2.

Requirements of the data transfer:

- a current program license of ROHR2 incl. ROHR2WIN
- the Interface PASCE-ROHR2
- the ROHR2 Neutral interface

The conversion is carried out in two steps:

- The PASCE Interface creates data in the format of the ROHR2 neutral interface. The scope of conversion depends on the parameters defined by PASCE.
- The created .NTR-file is read by the neutral interface (integrated in ROHR2WIN).

## 2.9 Export of graphics

### Export from ROHR2

Use the ROHR2 integrated dxf export command for the export of data in AUTOCAD compatible drawing format. The file, created is a 2D-dxf with limited modification capabilities.

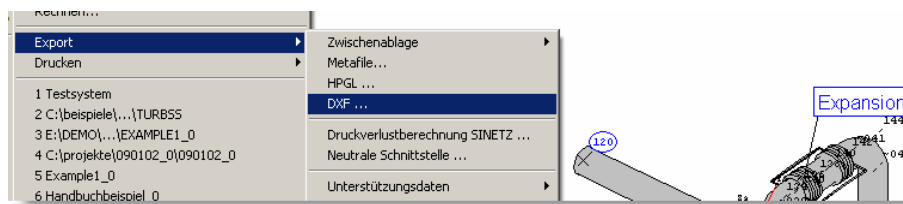

## 3 Interfaces to Steel construction programs

### 3.1 Interface SDFN - ROHR2

Interface to convert output data from SDFN format (Structural steel Detailing Neutral File) into the ROHR2 neutral interface format.

The interface SDFN - ROHR2 is an optional available program module to be integrated into ROHR2.

Requirements of the data transfer:

- a current program license of ROHR2 incl. ROHR2WIN
- the ROHR2 SDFN Interface
- the ROHR2 Neutral interface

The conversion is carried out in two steps:

- The SDFN Interface creates data in the format of the ROHR2 neutral interface.
- The created .NTR-file is read by the neutral interface (integrated in ROHR2WIN).

## 4 Interfaces to CAE-Systems

Currently the following CAE-systems are supported.

SINETZ	ROHR2-SINETZ Export Interface	see 4.1	included in ROHR2
CAESAR II	Interface ROHR2 - CAESAR II	see 4.2	included in ROHR2
Fluid dynamics	Import of Fluid hammer forces	see 4.4	included in ROHR2
LICAD (Lisega)	Export of support data	see 4.5	included in ROHR2
CASCADE (Witzenmann)	Export of support data	see 4.6	included in ROHR2
KWUROHR (Siemens)	Import Interface	see 4.3	optional available

Please ask for detailed information and sample files.

### 4.1 ROHR2 - SINETZ Export Interface

#### Fluid analysis (e.g. pressure loss calculation)

SINETZ, program for the steady state calculation of flow distribution, pressure drop and heat loss in branched and intermeshed piping networks for compressible and incompressible media.  
(Product of SIGMA Ingenieurgesellschaft mbH)

The SINETZ program normally includes a neutral interface to import data from CAD/CAE programs. It enables to import geometry data, dimensions, insulation, components like bends, instruments, pumps, reducers and orifices as well as boundary conditions (pressure, temperature and quantities).

The SINETZ neutral file format export interface is included in ROHR2.

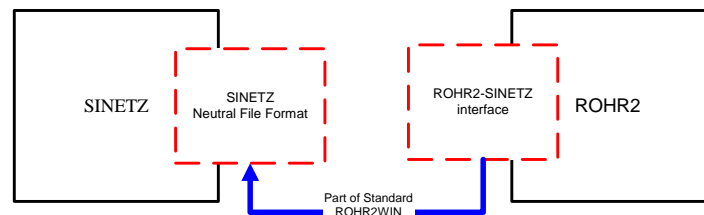

### 4.2 Interface ROHR2 - CAESAR II

Interface for the data exchange between ROHR2 and CAESAR II.  
Enables to read data in the format of the CAESAR II Neutral File. Nearly all import calculation data will be transmitted to be used by both of the program systems.

#### **Integrated Import-Interface**

The program system ROHR2 includes the interface to import CAESAR II calculation data. Data in the Caesar II neutral file format (\*.CII, Version 4.3 or higher) may be imported.

### 4.3 KWUROHR -ROHR2 Import Interface

Interface to convert input data for SIEMENS KWUROHR for the ROHR2 neutral interface format. The interface enables to import KWUROHR input files. The data of the KWUROHR model is converted into the ROHR2 neutral file, to be opened by ROHR2WIN. Load case depending data is not converted. Required file extension is \*.kwu (file must be renamed before if required).

Requirements of the data transfer:

- a current program license of ROHR2 incl. ROHR2WIN
- the Interface KWUROHR- ROHR2
- the ROHR2 Neutral interface

The conversion is carried out by two steps:

- To read kwurohr files use the *File| Open* command. Selected file type must be (\*.kwu).
- During this process the kwu-files are translated into the format of the neutral interface (see *Neutral interface - data import*). The scope of conversion depends on the parameters delivered by KWUROHR

The interface KWUROHR - ROHR2 is an optional available program module to be integrated into ROHR2/ROHR2win. For further details please refer to the separate manual, which is part of the interface software.

### 4.4 Fluid dynamic programs

#### ***Import of fluid hammer forces into ROHR2***

ROHR2 contains a format, defined for the import of fluid hammer forces. It enables the import of data of various fluid dynamic software, e.g. DRAKO and INROS. Please ask us for additional information.

### 4.5 Interface ROHR2 - LICAD

The interface ROHR2 - LICAD exports support data from ROHR2 into the hanger and support design system LICAD (LISEGA GmbH, [www.lisega.de](http://www.lisega.de)).

The interface ROHR2 - LICAD is included in the Program ROHR2 Static/Static and Dynamic. The design of supports will be prepared by the transfer of support data from ROHR2 into the planning system LICAD. A formatted text file is written, where all supports, to be exported, are listed. For each hanger the coordinates and maximum displacements and forces are given.

### 4.6 Interface ROHR2 - CASCADE

The interface ROHR2 - CASCADE exports support data from ROHR2 into the hanger and support design system CASCADE (Witzenmann GmbH, [www.witzenmann.de](http://www.witzenmann.de)).

The interface ROHR2 - CASCADE is included in the Program ROHR2 Static/Static and Dynamic

The design of supports will be prepared by the transfer of support data from ROHR2 into the planning system CASCADE. A formatted text file is written, where all supports, to be exported, are listed. For each hanger the coordinates and maximum displacements and forces are given.

Please ask for detailed information and sample files.

## 5 Third Party Interfaces

The integration of ROHR is supported by third-party interface products. In case of questions or information requests, please contact the manufacturer. We will be pleased to advise you regarding the data import and export to ROHR2.

For current information and links to software companies, please refer to our website [www.rohr2.com](http://www.rohr2.com).

AVEVA PDMS	<p><b>AVEVA PDMS-ROHR2 Interface</b> VE-Solutions GmbH Wilhelmstraße 72–74 D-68623 Lampertheim <a href="http://www.ve-solutions.de">www.ve-solutions.de</a></p> <p><b>AVEVA GmbH</b> Otto-Volger-Strasse 9 b D-65843 Sulzbach (Taunus) <a href="http://www.aveva-gmbh.de">www.aveva-gmbh.de</a></p>
ACPlant Designer	<p><b>ACPlant Designer ROHR2 Interface</b> ACPLANT CONSULT Software Development GmbH Helenenstraße 59-61/3/44, A-2500 Baden/Wien E-Mail: <a href="mailto:sales.a@ACPlant.com">sales.a@ACPlant.com</a>      <a href="http://www.acplant.com">www.acplant.com</a></p>
CADISON	<p><b>CADISON ROHR2 Interface</b> ITandFactory GmbH Auf der Krautweide 32, 65812 Bad Soden <a href="mailto:info@itandfactory.com">info@itandfactory.com</a>      <a href="http://www.itandfactory.com">www.itandfactory.com</a></p>
HICADnext	<p><b>HICAD - ROHR2- Interface</b> ISD Software und Systeme GmbH Hauert 4, D-44227 Dortmund <a href="mailto:info@isd cad.de">info@isd cad.de</a>      <a href="http://www.isd cad.com">www.isd cad.com</a></p>
RC-PLANET	<p><b>Plant Lifecycle Management</b> Planet GmbH Kammerstück 23, D-44357 Dortmund <a href="http://www.rc-planet.net">www.rc-planet.net</a>      <a href="http://www.plm-planet.com">www.plm-planet.com</a></p>
various CAD-systems supporting PCF-format, e.g. I-Sketch or Solid Edge with iso.EDGE	<p><b>UNITEC PCF4ROHR2</b> UNITEC Informationssysteme GmbH Rodenbacher Chaussee 6, D-63457 Hanau-Wolfgang Phone: +49 (0) 6181 94 54 0 <a href="mailto:info@unitec.de">info@unitec.de</a>      <a href="http://www.unitec.de">www.unitec.de</a></p>

Please note: the integration of external interfaces may require an upgrade/expansion of the program system ROHR2: the ROHR2 Neutral Interface is the main program module for the integration of CAD-programs (for details see 2.2).